

**A DIMENSION**

1 SLOT 2 SLOT 3 SLOT 4 SLOT

3/4"	1 7/8	3 5/8	5 5/16	7	<b>AGBA 75</b>
1"	2 1/8	4 1/8	6 1/16	8	<b>AGBA 100</b>
1 1/2"	2 5/8	5 1/8	7 9/16	10	<b>AGBA 150</b>

**MODEL:**

**AGBA**

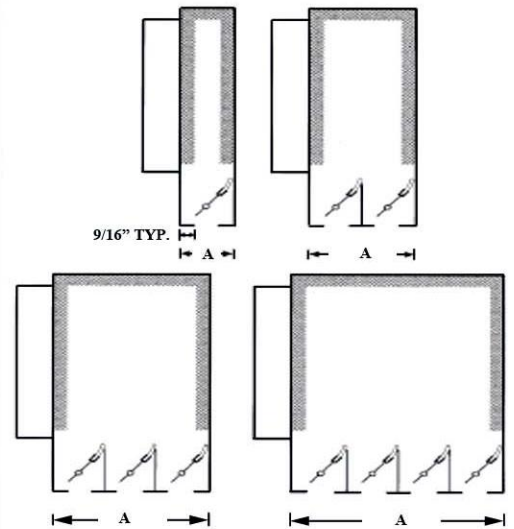

**AGBA**

Air diffuser with plenum

**DESCRIPTION:**

1. Designed for variable and constant volume systems-heated or cool air.
2. Full 180 degree diffusion-left, right, horizontal and vertical.
3. Maximum performance and flexibility-ideal for interior or perimeter installation.
4. Fully adjustable from the face-no field vane installation.
5. Low sound levels and minimum inlet pressure.
6. Compatible with a wide variety of suspended ceilings.
7. Felt seal on aluminum vanes restricts "dumping".

**OPTIONS:**

1. Finish

- ANOD Clear Anodized
- WHITE
- Medium Bronze
- Black
- Custom \_\_\_\_\_

2. Options:

- Face operated damper
- Center notch for 24" grid
- 1" insulation
- White face with black interior
- All white face and interior
- Off set inlet
- Open returns
- External insulation

**PROJECT:**

**ENGINEER:**

**CONTRACTOR:**

**DATE**

**SERIES**

**DRAWING NO.**