



ACCESSORIES

OPPOSED BLADE DAMPER

MODELS: DFR, EG

SUSTAINABLE EXTRUDED ALUMINUM

Dimensions are in inches

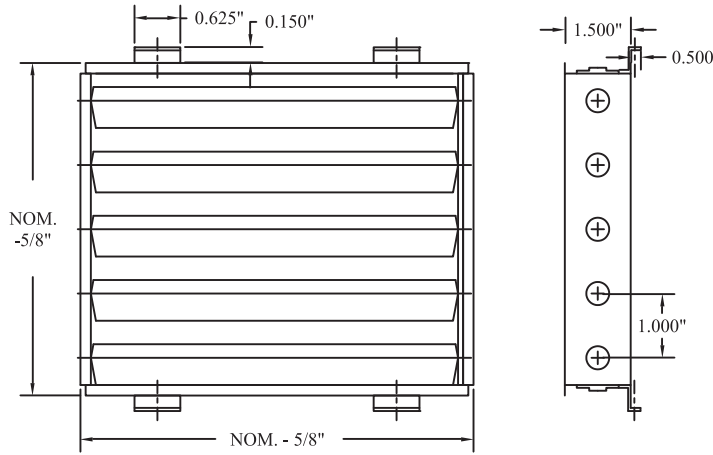

DFR

Duct mounted combination air straightener and equalizing grid.

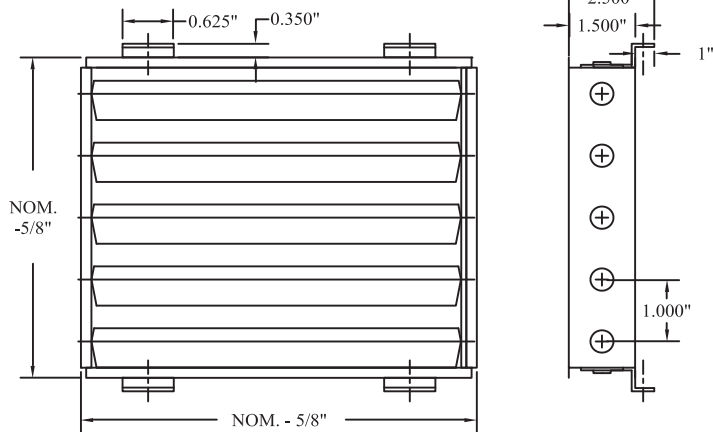

EG

Opposed blade damper with equalizing grid.

DESCRIPTION:

1. The model DFR is a duct-mounted combination air straightener and equalizing grid. All blades are individually adjustable. Available in square and rectangular configurations. All aluminum construction.
2. The model EG is 6063 extruded alloy. It utilizes 1-1/4" blades to provide uniform distribution of air across the face of the diffuser or grille. This Unit may be mounted directly on the grille itself or it may be duct-mounted by specifying a model EG-DM. All blades are individually adjustable and mounted into nylon bushings where the blades meet the frame.

Options:

OBFL (Fire link)

PROJECT:

ENGINEER:

CONTRACTOR:

DATE

SERIES

DRAWING NO.