



ACCESSORIES

OPPOSED BLADE DAMPER

MODELS: OB-DMR, OB-DMQ

SUSTAINABLE EXTRUDED ALUMINUM

Dimensions are in inches

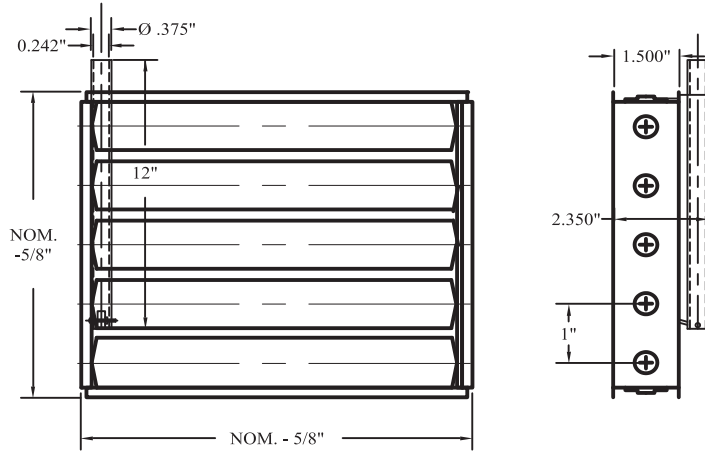

OB-DMR

Opposed blade damper with direct mount rod.

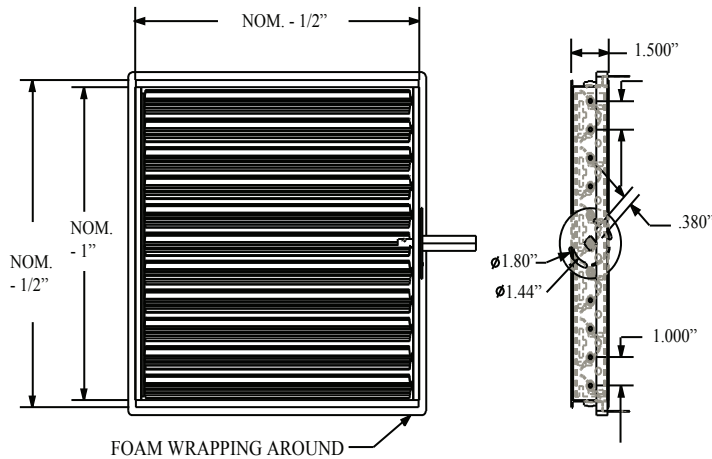

OB-DMQ

Opposed blade damper with direct mount square rod.

DESCRIPTION:

1. The model OB-DMR is identical in design to the model OB-L in that legs are mounted on the frame of the unit, and the blade adjustment of this model is accomplished with a 1/4" round rod. The rod extends through the duct in a fitting similar to the model SRP-14 ball-action Durodyne fitting, or a Young regulator model 950. These are not furnished by the factory.
2. The model DMQ's blade adjustment is accompanied by using a 3/8" square rod on the end of the unit that protrudes through the duct. There is a factory-furnished round disc which indicates the "OPEN" and "CLOSED" positions and mounts on the exterior of the duct.

Options:

OBFL (Fire link)

PROJECT:

ENGINEER:

CONTRACTOR:

DATE

SERIES

DRAWING NO.