

# RETURN FILTER GRILLES AND REGISTERS

RETURN FILTER GRILLES WITH ACCESS DOOR

MODELS: RF2-AD

SUSTAINABLE EXTRUDED ALUMINUM

Dimensions are in inches (mm)

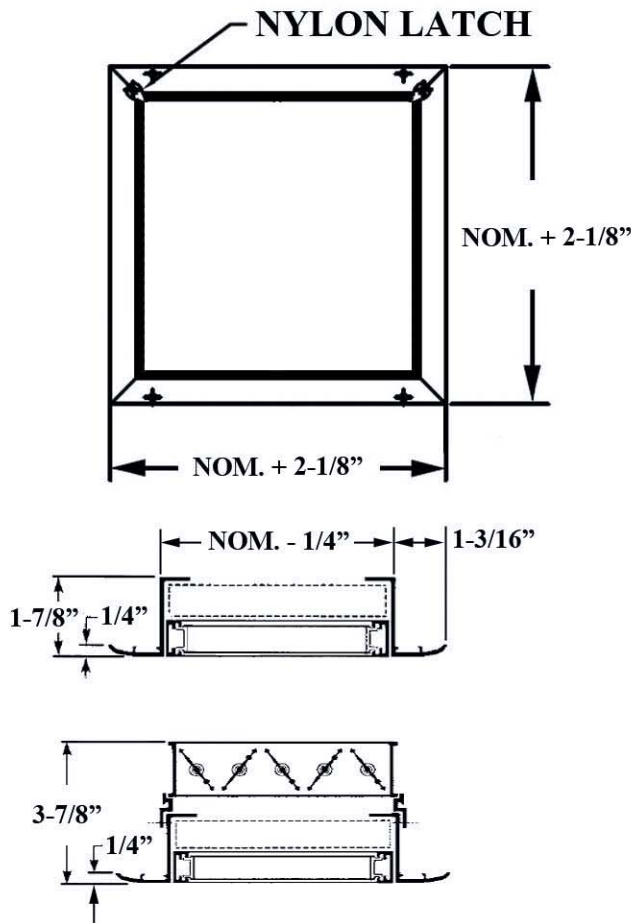

MODEL:

RF2-AD



RF2-AD

Return filter grille with access door.

**DESCRIPTION:**

1. The Model RF2-AD is assembled in a two-part system: one is the mounting frame that serves as a retainer for the filter, the other is the core that provides easy access to the filter. The core swings in and out of the mounting frame by means of two concealed pivot pins, and is held in place by two injection-molded nylon locking devices permanently attached to the mounting frame and located at the two corners opposite the pin side.
2. The core frame is separated from the blades by an extruded rigid PVC track that becomes an integral part of this frame. This method of assembly eliminates corrosion and vibration. The installation holes of the mounting frame are dimpled, allowing for a counter-sunk fastener head appearance.
3. An optional opposed blade damper is attached to the return grille with positive-locking spring clips. It has the same aluminum construction and is screwdriver-operated through the face of the unit.
4. Available in clear anodized, white or a variety of custom colors.

**OPTIONS:**

1. Finish
  - ANOD Clear Anodized
  - WHITE
  - MB Medium Bronze
  - B Black
  - Custom \_\_\_\_\_
2. Other
  - RF2FSME, RF2DSME
  - RF2FSMEOB
  - RF2OB-PLT, RF2-0°-OB-PLT, RF2CB-OB-PLT
  - RF2-P

PROJECT:

ENGINEER:

CONTRACTOR:

DATE

SERIES

DRAWING NO.