

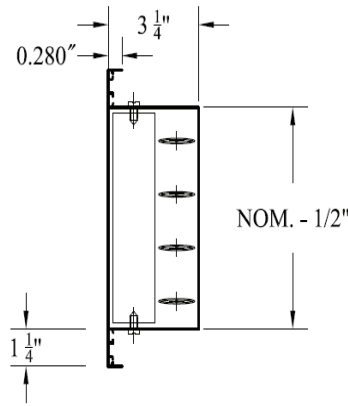

**INDUSTRIAL SUPPLY GRILLES SERIES**  
**AIRFOIL BLADE INDUSTRIAL SUPPLY GRILLES**  
**MODELS: VHAFS, HVAFS**

**SUSTAINABLE EXTRUDED ALUMINUM**

**Dimensions are in inches**

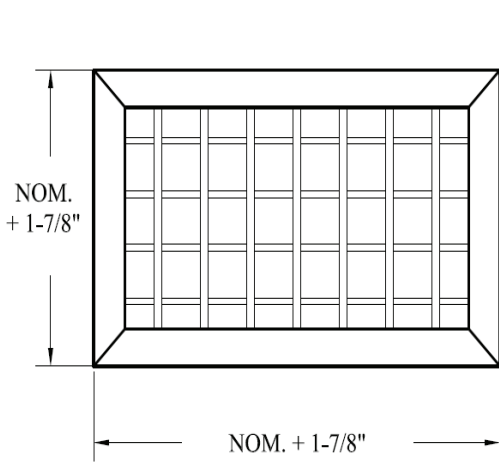

**VHAFS**

Standard Vertical Front Airfoil  
 Blades/Horizontal Rear Airfoil Blades.

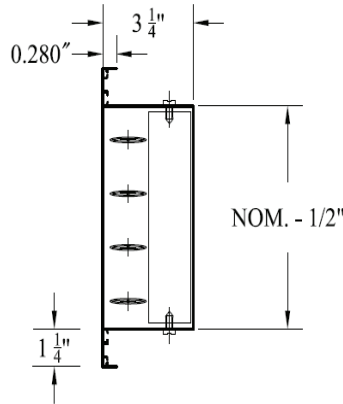
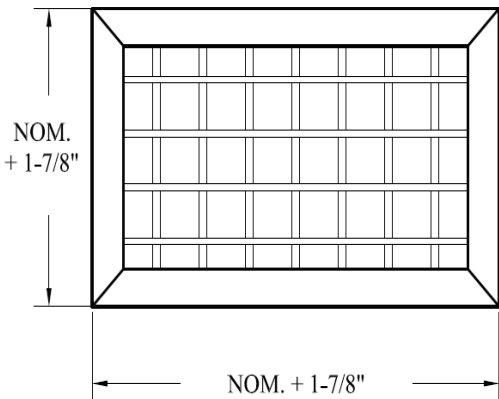

**HVAFA**

Standard Horizontal Front Airfoil  
 Blades/Vertical Rear Airfoil Blades.

**DESCRIPTION:**

1. Construction: 6063 Extruded aluminum frame mechanically interlocked with hairline mitered corner for strength. The frame has a typical wall thickness of .062" for maximum strength.
2. VHAF and HVAF are weather-resistant, strengthened supply grilles designed for wall installations.
3. Corner locks around four corners of the frame provide excellent tightening of the frame.
4. Standard finish is Mill.

**OPTIONS:**

1. Finish

- White
- ANOD Clear Anodized
- Medium Bronze
- Black
- Custom \_\_\_\_\_

2. Options

- OBFL (Fire link)
- PF (Plaster Frame)
- PLT

**PROJECT:**

**ENGINEER:**

**CONTRACTOR:**

**DATE**

**SERIES**

**DRAWING NO.**