



**INDUSTRIAL SUPPLY GRILLES SERIES**

SINGLE DEFLECTION INDUSTRIAL SUPPLY GRILLES AND REGISTERS

MODELS: VME-I, VME-I-OB, HME-I, HME-I-OB

**SUSTAINABLE EXTRUDED ALUMINUM**

**Dimensions are in inches**

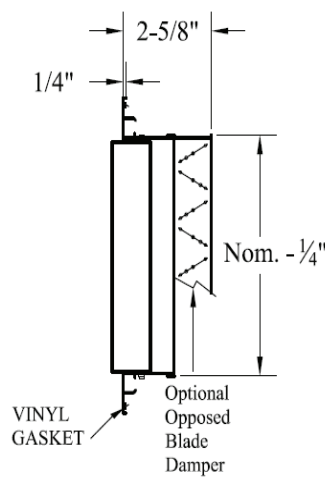
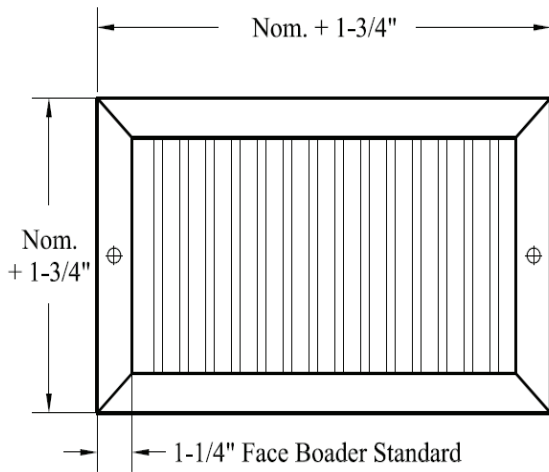

**VME-I**

Single Deflection Industrial Supply Grille with Vertical Blades and with Square Contour Frame.

**VME-I-OB**

Single Deflection Industrial Supply Register with Vertical Blades and with Square Contour Frame (includes OB Damper).

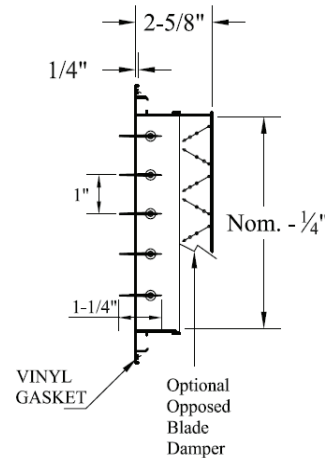
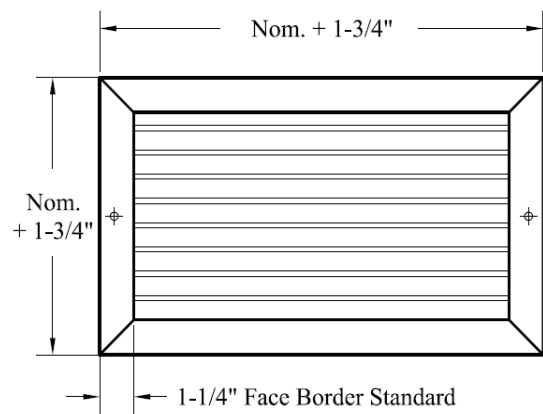

**HME-I**

Single Deflection Industrial Supply Grille with Front Blades Parallel to the Horizontal Dimension and with Square Contour Frame.

**HME-I-OB**

Single Deflection Industrial Supply Register with Front Blades Parallel to the Horizontal Dimension and with Square Contour Frame (includes OB Damper).

**DESCRIPTION:**

1. Construction: 6063 Extruded aluminum frame mechanically interlocked with hairline mitered corner for strength. A single set of 6063 extruded aluminum blades on with 3/4" spacing provides air control in a single plane. Blades are individually adjustable with zero metal-to-metal contact with the use of nylon bushings to eliminate noise, corrosion and vibration. Extruded flexible vinyl gasket is standard and produces a perfect positive air seal.
2. Optional screwdriver operated opposed blade damper with nylon bushings.
3. Minimum size: 4" x 4"  
Maximum size: 48" x 48"  
For larger and fractional sizes, consult factory.

**OPTIONS:**

1. Finish
  - White
  - ANOD Clear Anodized
  - Medium Bronze
  - Black
  - Custom \_\_\_\_\_
2. Options
  - OBFL (Fire link)
  - PF (Plaster Frame)
  - PLT
3. Frame style
  - Beveled Frame Available
  - ME (square contour) Frame

**PROJECT:**

**ENGINEER:**

**CONTRACTOR:**

**DATE**

**SERIES**

**DRAWING NO.**