

**Performance Data**  
**Heavy Duty Return Grilles and Registers • 45° Deflection**  
**Models: HDRA**

Listed Duct Size (inches)	Alternate Size (inches)	Core Area (sq. ft.)	Ak Factor	Core Velocity VP Neg. SP	100	200	300	400	500	600	700	800	900	1000
					.001 .005	.002 .021	.006 .046	.010 .082	.016 .129	.022 .185	.031 .252	.040 .330	.050 .417	.062 .515
6 x 6	8 x 4 10 x 4	0.20	0.23	CFM	20	40	60	80	100	120	140	160	180	200
				NC	-	-	-	15	20	25	30	34	38	42
8 x 6	10 x 5 12 x 4	0.28	0.30	CFM	28	56	84	112	140	168	196	224	252	280
				NC	-	-	-	16	21	26	31	35	39	43
10 x 6	12 x 5 16 x 4	0.35	0.37	CFM	35	70	105	140	175	210	245	280	315	350
				NC	-	-	-	17	22	27	32	36	40	44
8 x 8	14 x 5	0.38	0.40	CFM	38	76	114	152	190	228	266	304	342	380
				NC	-	-	-	18	23	28	33	37	41	45
12 x 6	18 x 4	0.42	0.45	CFM	42	84	126	168	210	252	294	336	378	420
				NC	-	-	-	19	24	29	33	38	42	46
12 x 8	16 x 6 24 x 4	0.58	0.59	CFM	58	116	174	232	290	348	406	464	522	580
				NC	-	-	15	20	25	30	34	39	43	47
10 x 10	14 x 7 26 x 4	0.61	0.62	CFM	61	122	183	244	305	366	427	488	549	610
				NC	-	-	15	20	25	30	35	40	43	47
18 x 6	14 x 8    30 x 4 28 x 4	0.65	0.67	CFM	65	130	195	260	325	390	455	520	585	650
				NC	-	-	15	21	26	31	36	40	44	47
12 x 10	16 x 8    20 x 6 24 x 5	0.74	0.74	CFM	74	148	222	296	370	444	518	592	666	740
				NC	-	-	16	21	26	31	36	41	45	48
12 x 12	14 x 10    24 x 6 18 x 8    38 x 4	0.90	0.89	CFM	90	180	270	360	450	540	630	720	810	900
				NC	-	-	17	22	27	32	37	42	45	48
14 x 14	16 x 12    24 x 8 20 x 10    34 x 6	1.24	1.22	CFM	124	248	372	496	620	744	868	992	1116	1240
				NC	-	-	18	22	27	32	37	42	46	49
18 x 12	16 x 14    28 x 8 22 x 10    38 x 6	1.37	1.34	CFM	137	274	411	548	685	822	959	1096	1233	1370
				NC	-	-	19	24	29	34	39	44	47	50
24 x 10	20 x 12 30 x 8	1.52	1.49	CFM	152	304	456	608	760	912	1064	1216	1368	1520
				NC	-	-	19	24	29	34	39	45	48	51
16 x 16	18 x 14    30 x 8 22 x 12	1.64	1.58	CFM	164	328	492	656	820	984	1148	1312	1476	1640
				NC	-	-	20	25	30	35	40	45	48	51
24 x 12	18 x 16    30 x 10 20 x 14    36 x 8	1.85	1.78	CFM	185	370	555	740	925	1110	1295	1480	1665	1850
				NC	-	15	20	25	30	35	40	45	48	52
18 x 18	20 x 16    28 x 12 24 x 14    32 x 10	2.10	2.01	CFM	210	420	630	840	1050	1260	1470	1680	1890	2100
				NC	-	15	20	25	30	36	41	46	49	52
30 x 12	20 x 18    26 x 14 22 x 16    36 x 10	2.32	2.23	CFM	232	464	696	928	1160	1392	1624	1856	2088	2320
				NC	-	15	20	26	31	36	41	46	49	53
20 x 20	24 x 18    30 x 14 26 x 16    36 x 12	2.61	2.48	CFM	261	522	783	1044	1305	1566	1827	2088	2349	2610
				NC	-	15	20	26	31	37	42	47	50	53
22 x 22	24 x 20    30 x 16 26 x 18    36 x 14	3.17	3.00	CFM	317	634	951	1268	1585	1902	2219	2536	2853	3170
				NC	-	16	21	27	32	38	42	47	50	54
30 x 18	24 x 22    40 x 14 34 x 16	3.54	3.34	CFM	354	708	1062	1416	1770	2124	2478	2832	3186	3540
				NC	-	16	21	27	32	38	43	48	51	55
24 x 24	26 x 22    32 x 18 28 x 20    36 x 16	3.79	3.56	CFM	379	758	1137	1516	1895	2274	2653	3032	3411	3790
				NC	-	16	21	27	32	38	43	48	51	55
36 x 18	32 x 20    46 x 14 40 x 16	4.27	4.01	CFM	427	854	1281	1708	2135	2562	2989	3416	3843	4270
				NC	-	17	22	29	34	40	45	50	53	57
26 x 26	28 x 24 48 x 14	4.47	4.19	CFM	447	894	1341	1788	2235	2682	3129	3576	4023	4470
				NC	-	17	22	29	34	40	45	50	53	57
30 x 24	28 x 26    36 x 20 32 x 22    40 x 18	4.77	4.46	CFM	477	954	1431	1908	2385	2862	3339	3816	4293	4770
				NC	-	18	23	30	35	41	46	50	54	58
28 x 28	30 x 26    40 x 20 36 x 22	5.20	4.85	CFM	520	1040	1560	2080	2600	3120	3640	4160	4680	5200
				NC	-	18	23	30	35	41	46	51	54	58

## Performance Data

### Heavy Duty Return Grilles and Registers • 45° Deflection

#### Models: HDRA

Listed Duct Size (inches)	Alternate Size (inches)	Core Area (sq. ft.)	Ak Factor	Core Velocity VP Neg. SP	100	200	300	400	500	600	700	800	900	1000
					.001 .005	.002 .021	.006 .046	.010 .082	.016 .129	.022 .185	.031 .252	.040 .330	.050 .417	.062 .515
36 x 24	30 x 28 40 x 22	5.74	5.35	CFM	574	1148	1722	2296	2870	3444	4018	4592	5166	5740
				NC	—	18	23	30	36	42	47	51	55	59
30 x 30	34 x 26 38 x 24	5.99	5.57	CFM	599	1198	1797	2396	2995	3594	4193	4792	5391	5990
				NC	—	18	23	30	36	42	47	51	55	59
32 x 32	36 x 30 38 x 28	6.84	6.34	CFM	684	1368	2052	2736	3420	4104	4788	5472	6156	6840
				NC	15	19	24	31	37	43	47	52	56	60
48 x 24	34 x 34 36 x 32	7.69	7.13	CFM	769	1538	2307	3076	3845	4614	5383	6152	6921	7690
				NC	16	20	25	31	37	43	48	52	56	60
36 x 36	38 x 34 42 x 30	8.69	8.02	CFM	869	1738	2607	3476	4345	5214	6083	6952	7821	8690
				NC	17	21	25	32	37	44	49	53	57	61
38 x 38	42 x 34 44 x 34	9.70	8.94	CFM	970	1940	2910	3880	4850	5820	6790	7760	8730	9700
				NC	17	22	26	32	38	44	49	53	57	61
40 x 40	42 x 36 46 x 34	10.77	9.90	CFM	1077	2154	3231	4308	5385	6462	7539	8616	9693	10770
				NC	17	22	27	33	39	45	51	54	59	63
42 x 42	44 x 40 46 x 38	11.89	10.92	CFM	1189	2378	3567	4756	5945	7134	8323	9512	10701	11890
				NC	18	23	28	34	40	46	51	55	59	63
44 x 44	46 x 42	13.07	11.98	CFM	1307	2614	3921	5228	6535	7842	9149	10456	11763	13070
				NC	18	23	28	34	40	46	51	55	59	63
46 x 46		14.30	13.10	CFM	1430	2860	4290	5720	7150	8580	10010	11440	12870	14300
	NC			19	24	29	35	41	47	52	56	60	64	
48 x 48		15.59	14.26	CFM	1559	3118	4677	6236	7795	9354	10913	12472	14031	15590
	NC			19	24	29	35	41	47	52	56	60	64	

- CFM** - cubic feet per minute  
**VP** - velocity pressure - inches w.g.  
**Neg. SP** - negative static pressure - inches w.g.  
**NC** - Noise Criteria values are based on 10 dB room absorption, re 10<sup>-12</sup> watts.

Core Velocity is in feet per minute.

#### Performance Notes:

1. Performance data is for grille with opposed blade damper. Apply the following correction factors for grille without damper.

**Neg. SP** Listed Value x 0.91.

**NC** Listed value - 4.

2. Data derived from tests conducted in accordance with ANSI/ASHRAE Standard 70 - 2006.

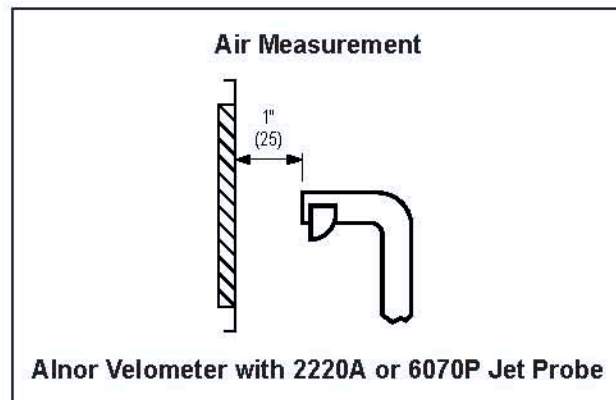

#### Airflow Measurements

- Balancing factors are applicable with or without dampers, providing uniform airflow exists into grille or register.
- Take velocity readings at a number of locations on the inlet face (a minimum of 4), while positioning probe as shown above, one inch out from the face.
- Total the various velocity readings and divide by the number of readings taken to arrive at an average inlet velocity (V<sub>k</sub> in FPM).
- Calculate the airflow (CFM) by multiplying the average velocity by the appropriate Ak factor.  
**Airflow (CFM) = Average velocity (V<sub>k</sub>) x Ak.**



**Performance Data**  
**Heavy Duty Return Grilles and Registers • 0° Deflection**  
**Models: HDRAO**

Listed Duct Size (inches)	Alternate Size (inches)	Core Area (sq. ft.)	Ak Factor	Core Velocity VP Neg. SP	100	200	300	400	500	600	700	800	900	1000
					.001 .002	.002 .009	.006 .020	.010 .036	.016 .057	.022 .082	.031 .111	.040 .145	.050 .183	.062 .226
6 x 6	8 x 4 10 x 4	0.20	0.23	CFM	20	40	60	80	100	120	140	160	180	200
				NC	-	-	-	-	18	20	23	27	32	
8 x 6	10 x 5 12 x 4	0.28	0.30	CFM	28	56	84	112	140	168	196	224	252	280
				NC	-	-	-	-	15	19	21	24	28	33
10 x 6	12 x 5 16 x 4	0.35	0.37	CFM	35	70	105	140	175	210	245	280	315	350
				NC	-	-	-	-	16	20	22	25	29	34
8 x 8	14 x 5	0.38	0.40	CFM	38	76	114	152	190	228	266	304	342	380
				NC	-	-	-	-	16	21	23	26	30	34
12 x 6	18 x 4	0.42	0.45	CFM	42	84	126	168	210	252	294	336	378	420
				NC	-	-	-	-	17	21	24	27	31	35
12 x 8	16 x 6 24 x 4	0.58	0.59	CFM	58	116	174	232	290	348	406	464	522	580
				NC	-	-	-	-	17	21	24	28	32	36
10 x 10	14 x 7 26 x 4	0.61	0.62	CFM	61	122	183	244	305	366	427	488	549	610
				NC	-	-	-	-	17	21	24	29	32	37
18 x 6	14 x 8    30 x 4 28 x 4	0.65	0.67	CFM	65	130	195	260	325	390	455	520	585	650
				NC	-	-	-	-	18	22	25	29	33	37
12 x 10	16 x 8    20 x 6 24 x 5	0.74	0.74	CFM	74	148	222	296	370	444	518	592	666	740
				NC	-	-	-	-	18	23	26	30	34	37
12 x 12	14 x 10    24 x 6 18 x 8    38 x 4	0.90	0.89	CFM	90	180	270	360	450	540	630	720	810	900
				NC	-	-	-	-	19	23	26	31	34	37
14 x 14	16 x 12    24 x 8 20 x 10    34 x 6	1.24	1.22	CFM	124	248	372	496	620	744	868	992	1116	1240
				NC	-	-	-	-	19	24	27	31	35	38
18 x 12	16 x 14    28 x 8 22 x 10    38 x 6	1.37	1.34	CFM	137	274	411	548	685	822	959	1096	1233	1370
				NC	-	-	-	-	20	25	28	33	36	39
24 x 10	20 x 12    30 x 8	1.52	1.49	CFM	152	304	456	608	760	912	1064	1216	1368	1520
				NC	-	-	-	-	15	20	25	29	34	37
16 x 16	18 x 14    30 x 8 22 x 12	1.64	1.58	CFM	164	328	492	656	820	984	1148	1312	1476	1640
				NC	-	-	-	-	16	21	25	29	34	37
24 x 12	18 x 16    30 x 10 20 x 14    36 x 8	1.85	1.78	CFM	185	370	555	740	925	1110	1295	1480	1665	1850
				NC	-	-	-	-	16	21	26	29	34	37
18 x 18	20 x 16    28 x 12 24 x 14    32 x 10	2.10	2.01	CFM	210	420	630	840	1050	1260	1470	1680	1890	2100
				NC	-	-	-	-	16	21	26	30	35	38
30 x 12	20 x 18    26 x 14 22 x 16    36 x 10	2.32	2.23	CFM	232	464	696	928	1160	1392	1624	1856	2088	2320
				NC	-	-	-	-	16	21	26	30	35	38
20 x 20	24 x 18    30 x 14 26 x 16    36 x 12	2.61	2.48	CFM	261	522	783	1044	1305	1566	1827	2088	2349	2610
				NC	-	-	-	-	16	21	26	30	35	38
22 x 22	24 x 20    30 x 16 26 x 18    36 x 14	3.17	3.00	CFM	317	634	951	1268	1585	1902	2219	2536	2853	3170
				NC	-	-	-	-	17	22	27	31	35	38
30 x 18	24 x 22    40 x 14 34 x 16	3.54	3.34	CFM	354	708	1062	1416	1770	2124	2478	2832	3186	3540
				NC	-	-	-	-	17	22	27	31	36	39
24 x 24	26 x 22    32 x 18 28 x 20    36 x 16	3.79	3.56	CFM	379	758	1137	1516	1895	2274	2653	3032	3411	3790
				NC	-	-	-	-	17	22	27	32	36	39
36 x 18	32 x 20    46 x 14 40 x 16	4.27	4.01	CFM	427	854	1281	1708	2135	2562	2989	3416	3843	4270
				NC	-	-	-	-	19	24	28	32	37	40
26 x 26	28 x 24 48 x 14	4.47	4.19	CFM	447	894	1341	1788	2235	2682	3129	3576	4023	4470
				NC	-	-	-	-	19	24	28	32	37	40
30 x 24	28 x 26    36 x 20 32 x 22    40 x 18	4.77	4.46	CFM	477	954	1431	1908	2385	2862	3339	3816	4293	4770
				NC	-	-	-	-	20	25	29	33	37	41
28 x 28	30 x 26    40 x 20 36 x 22	5.20	4.85	CFM	520	1040	1560	2080	2600	3120	3640	4160	4680	5200
				NC	-	-	-	-	20	25	29	33	38	41

## Performance Data

### Heavy Duty Return Grilles and Registers • 0° Deflection

#### Models: HDRAO

Listed Duct Size (inches)	Alternate Size (inches)	Core Area (sq. ft.)	Ak Factor	Core Velocity VP Neg. SP	100	200	300	400	500	600	700	800	900	1000
					.001	.002	.006	.010	.016	.022	.031	.040	.050	.062
36 x 24	30 x 28 44 x 20	5.74	5.35	CFM	574	1148	1722	2296	2870	3444	4018	4592	5166	5740
				NC	—	—	—	20	25	29	33	38	42	46
30 x 30	34 x 26 48 x 20	5.99	5.57	CFM	599	1198	1797	2396	2995	3594	4193	4792	5391	5990
				NC	—	—	—	20	25	30	34	38	42	46
32 x 32	36 x 30 46 x 22	6.84	6.34	CFM	684	1368	2052	2736	3420	4104	4788	5472	6156	6840
				NC	—	—	—	20	26	30	34	39	43	47
48 x 24	34 x 34 38 x 30	7.69	7.13	CFM	769	1538	2307	3076	3845	4614	5383	6152	6921	7690
				NC	—	—	—	20	26	31	35	39	43	47
36 x 36	38 x 34 46 x 28	8.69	8.02	CFM	869	1738	2607	3476	4345	5214	6083	6952	7821	8690
				NC	—	—	—	21	26	31	36	40	44	48
38 x 38	42 x 34 48 x 30	9.70	8.94	CFM	970	1940	2910	3880	4850	5820	6790	7760	8730	9700
				NC	—	—	—	21	27	32	36	40	44	48
40 x 40	42 x 36 48 x 32	10.77	9.90	CFM	1077	2154	3231	4308	5385	6462	7539	8616	9693	10770
				NC	—	—	—	22	28	32	37	40	45	49
42 x 42	44 x 40 48 x 36	11.89	10.92	CFM	1189	2378	3567	4756	5945	7134	8323	9512	10701	11890
				NC	—	—	—	22	28	33	37	41	45	49
44 x 44	46 x 42	13.07	11.98	CFM	1307	2614	3921	5228	6535	7842	9149	10456	11763	13070
				NC	—	—	—	17	22	28	33	37	41	45
46 x 46		14.30	13.10	CFM	1430	2860	4290	5720	7150	8580	10010	11440	12870	14300
	NC			—	—	—	17	23	29	34	38	42	46	50
48 x 48		15.59	14.26	CFM	1559	3118	4677	6236	7795	9354	10913	12472	14031	15590
	NC			—	—	—	18	23	29	34	38	42	46	50

**CFM** - cubic feet per minute

**VP** - velocity pressure - inches w.g.

**Neg. SP** - negative static pressure - inches w.g.

**NC** - Noise Criteria values are based on 10 dB room absorption, re 10<sup>-12</sup> watts.

Core Velocity is in feet per minute.

#### Performance Notes:

1. Performance data is for grille with opposed blade damper. Apply the following correction factors for grille without damper.

**Neg. SP** Listed Value x 0.91.

**NC** Listed value - 4.

2. Data derived from tests conducted in accordance with ANSI/ASHRAE Standard 70 - 2006.

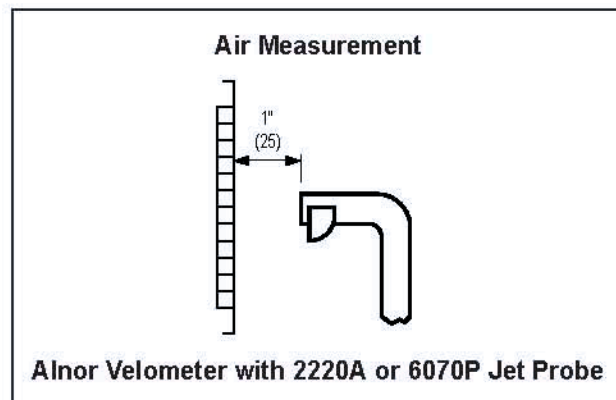

#### Airflow Measurements

- Balancing factors are applicable with or without dampers, providing uniform airflow exists into grille or register.
- Take velocity readings at a number of locations on the inlet face (a minimum of 4), while positioning probe as shown above, one inch out from the face.
- Total the various velocity readings and divide by the number of readings taken to arrive at an average inlet velocity (V<sub>k</sub> in FPM).
- Calculate the airflow (CFM) by multiplying the average velocity by the appropriate Ak factor.  
Airflow (CFM) = Average velocity (V<sub>k</sub>) x Ak.